

Legendary
Quality
Since 1930





About General Floorcraft

ALL METAL CONSTRUCTION



SOLID CAST ALUMINUM ASK YOURSELF, WHAT'S YOUR MACHINE MADE OF?

We use only the highest quality premium motors and gearboxes. Our legendary quality delivers a supremely balanced and whisper-quiet performance, this results in a long lasting and very reliable floor equipment. The success of our company depends on more than just making great products but also delivering outstanding customer service.



KC Series

**HEAVY DUTY
FLOOR
MACHINE**



The KC series features four durable models to choose from.

This Heavy Duty machine strips, scrubs, cleans, polishes, buffs and shampoos. It is the perfect choice for cleaning and maintenance professionals.

- Cool running powerful 1 hp motor. 120 or 220 volts with dual capacitors.
- One piece 360 degree non-marking bumper.
- 6" shock absorbing flip up non-marking wheels.
- Unique **Pivot System** for precision balance and maneuverability.
- All cast aluminum with chrome handle.
- Solution tank "ready" system.
- Includes red safety cable with waterproof jacket.
- Dual non-conductive switch lever.
- 5 years motor and gear box warranty.

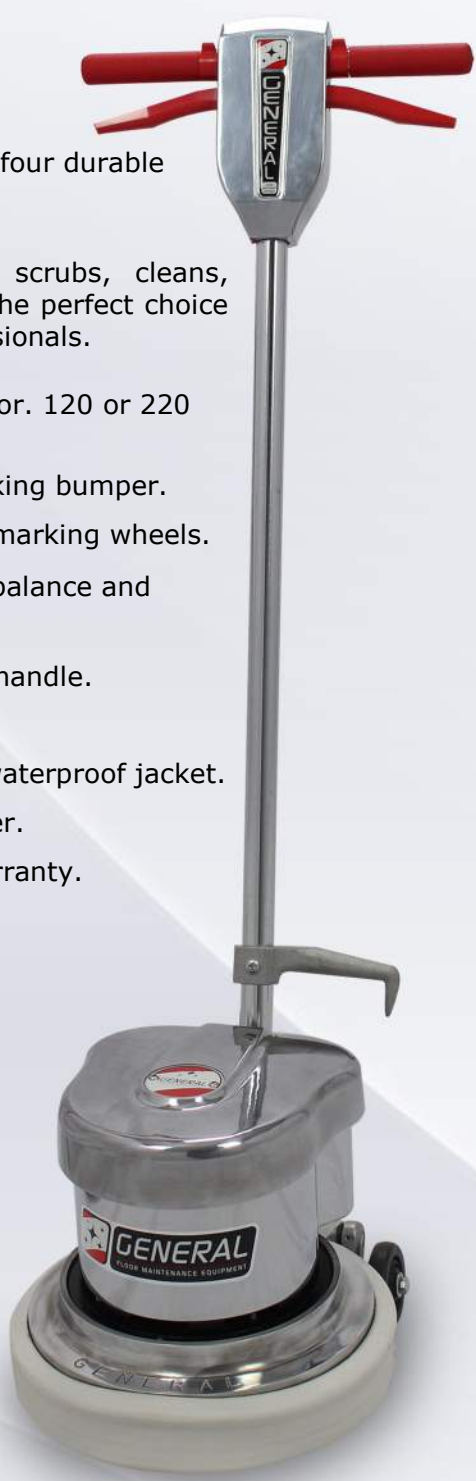

KC Series	Cable	Current	Gear Box	Motor AC	Pad Size	Pad Speed	Productivity	Weight
KC-13	25 ft (15.2 m)	12.6 amp (120V) / 6.8 amp (230V) - 50Hz	Dual Planetary	1.0 hp (746 w)	13" (33 cm)	175 rpm	1,976 ft ² /hr	91 lbs (41.3 kg)
KC-17	50 ft (15.2 m)	12.6 amp (120V) / 6.8 amp (230V) - 50Hz	Dual Planetary	1.0 hp (746 w)	17" (43.2 cm)	175 rpm	2,000 ft ² /hr	98 lbs (44.5 kg)
KC-19	50 ft (15.2 m)	12.6 amp (120V) / 6.8 amp (230V) - 50Hz	Dual Planetary	1.0 hp (746 w)	19" (48.2 cm)	175 rpm	2,448 ft ² /hr	107 lbs (48.5 kg)
KC-21	50 ft (15.2m)	12.6 amp (120V) / 6.8 amp (230V) - 50Hz	Dual Planetary	1.0 hp (746 w)	21" (53.3 cm)	175 rpm	3,000 ft ² /hr	114 lbs (51.7 kg)

*Brushes, pads, pad drivers and solution tank available.



Solution Tank

ACCESSORIES

Our 4 gallon solution tank for our line of floor machines, features brass hardware and a flow control valve that allows operators to properly manage the amount of solution used during cleaning. An extra-wide opening makes tank filling easier and helps prevent chemical spills. Our machines are Intertek certified with the solution tank on them.

- Mounting hardware included.
- Durable construction.
- 4 gallon capacity.
- See-thru tank.
- Easy to set up.
- Solution control valve.



Brushes & Pads

ACCESSORIES

Full line of rotary brushes available. Including pad drivers, scrubbing brushes, carpet shampoo brushes, grit brushes and specialty brushes for stone and concrete. Whether the application is stripping, general scrubbing, or hard surface polishing, General Floorcraft offers a diverse line of material options including nylon, polypropylene, wire, natural fiber and specialty brushes.





In 1930 General Floorcraft created the unique Pivot System and incorporated it into a one piece apron for It's the floor machine line. It has pivot pins, bars, links and adaptors to balance the machine and take the weight off the handle and relieve the motor and operator of stress. This system provides the perfect balance of the handle for a much easier and smooth operation.

Pivot System

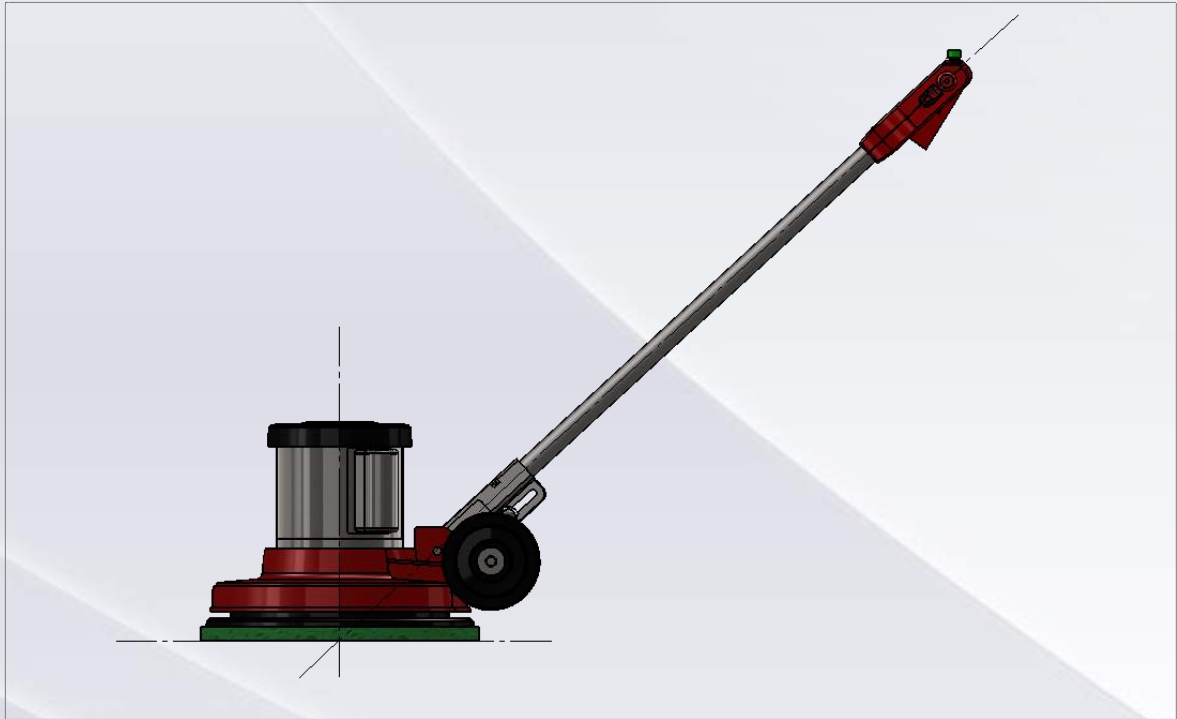

APPROVED FOR FABRICATION BY:				Material	DATE	GENERAL FLOORCRAFT INC.	
PRINT NAME:			TOLERANCES:	DRAWN	C.H.M.	5/21/2011	
DATE:			FRACTIONAL ± 1/8" & 1/4"	CHECKED			6512 NW 99 Ave. (305) 477-1557 Phone
			ANGULAR ± 1/2°	ENCAPPE.			Doral, FL 33176 (305) 477-1559 Fax
			DECIMAL ±.005	ANC APPE.			
				Q.A.			Machine Assembly
PROPRIETARY AND CONFIDENTIAL THE INFORMATION CONTAINED IN THIS DRAWING IS THE SOLE PROPERTY OF GENERAL FLOORCRAFT INC. ANY REPRODUCTION IN PART OR AS A WHOLE WITHOUT THE WRITTEN PERMISSION OF GENERAL FLOORCRAFT INC. IS PROHIBITED.			MATERIAL	COMMENTS:			
			FINISH	SEE DHC. NO.			REV.
			APPLICATION	SCALE: 1/2"	DRAWN:		SHEET OF 1



6312 NW 99th Ave. Miami, FL 33178.

Phone: 305-477-1557 / Fax: 305-477-1558

www.genfloor.com